



# **XBODY** - Conical Connection Implant

AVAILABLE IMPLANT SYSTEMS



INTERNAL  
HEX.



CONICAL  
CONNECTION



EXTERNAL  
HEX.

# Index



How to consult this catalogue	3
About us	4
Innovation, precision and quality	5
Vulkan® Conical Connection Xbody	6
Tested Benefits	7
VLA® Surface Treatment and Plasma Cleaning	8
Technical Specifications	10
Measurement Guide and Odontogram	11
Indications for the use of the MiP platform	12
Indications on Vulkan Tissue Care	13
Technical specifications - Titanium 4	14
Prior Information on Surgical Protocol	15
Surgical Protocol	16
Implant Driver and Packaging	18
Implant placement step by step	19
Prosthetic Solutions and Tools	
Basic components	23
Multi-Use® Transepithelial System	25
Tissue Care Transepithelial System	26
VulkanLoc® Overdenture System	28
CAD-CAM Components	29
Prosthetic and Surgical Tools	30
Advanced Surgical Kit	31

# How to consult this catalog

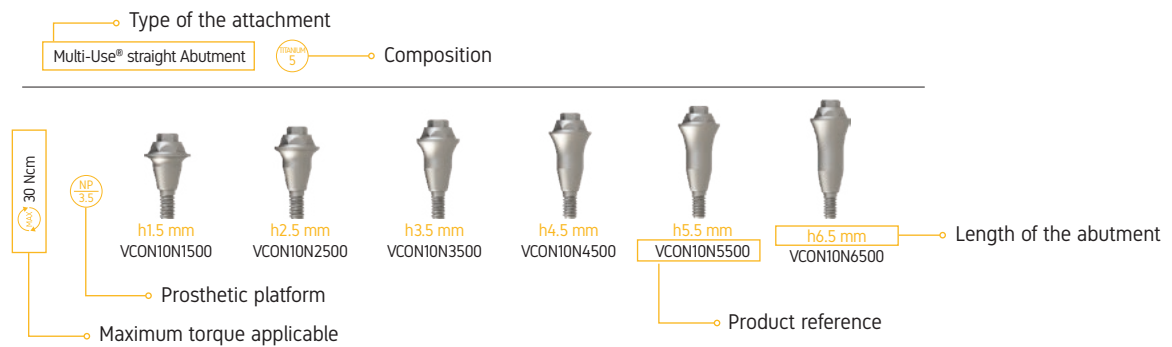
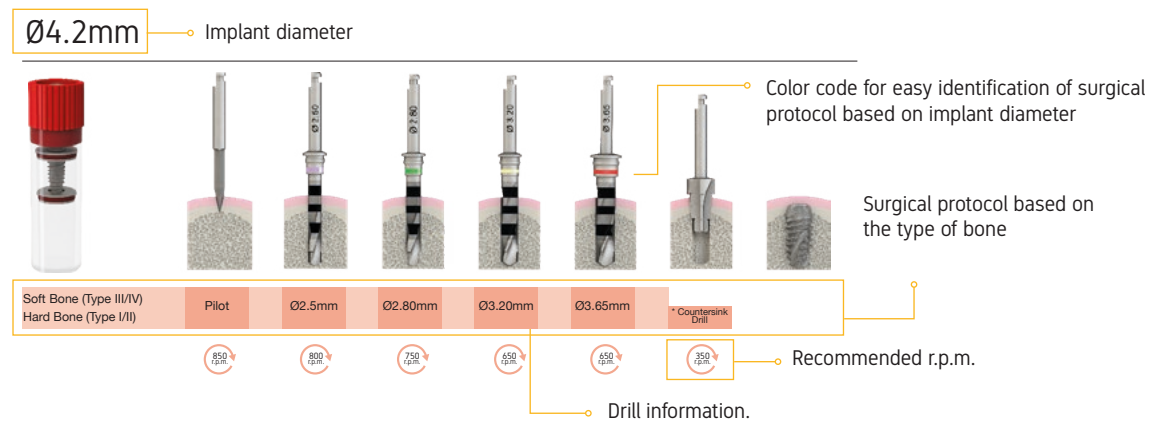
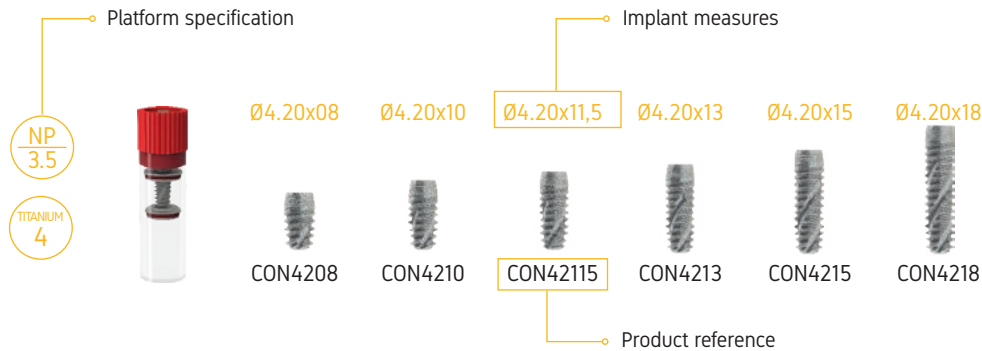

## Symbology

- = Mini Platform
- = TiN Coating
- = Unigrip connection
- = More info available in our site
- = Narrow Platform
- = Machined in POM
- = Non-Engaging
- = Revolutions per minute
- = Titanium Grade 4
- = Cobalt Chrome
- = Engaging
- = Angle of inclination
- = Titanium Grade 5
- = Stainless Steel
- = Maximum Torque
- = Tetralobular connection
- = DLC Coating
- = Machined in PEEK
- = Use of irrigation



**VULKAN**  
DENTAL IMPLANTS  
Strongly with you

About  
Us

Designed and made in Barcelona,  
one of the most advanced cities in the world in biotechnology

**Vulkan®** is a modern, cutting-edge **European dental implant brand**, established in Barcelona (Spain) in 2013.

**Vulkan®** was born out of our long and recognized expertise in the field of dental implantology. Also, because of our links with highly regarded companies and professionals in the sector and our close ties with the strong and world-renowned local biotechnological network.

As a manufacturer of implants and dental prosthetic solutions, our added value is based on the **high quality and reliability** of our processes and products. As well as the innovative capacity of our team of scientists, engineers and dental professionals.

In **Vulkan®** we carefully monitor and control all our processes of R+D+i, design, production and quality to be able to guarantee 100% the success of our products.

Our mission is to improve and facilitate the experience of the patients and dental health professionals by designing, manufacturing and making more accessible the most up-to-date dental implant technology.

#### **Innovation:**

The constant improvement and the desire to find the best solutions for the patients place us as an innovative and reliable company.

#### **Quality:**

Quality and seeking perfection are golden rules for everything we do.

#### **Commitment:**

Our commitment with the patients: solutions that improve their quality of life.

Our commitment with the industry professionals: innovations to improve their clinical experience.

#### **Added value:**

The engine that moves us forward is the motivation to always offer more and better solutions.

#### **Sustainability:**

For us sustainability is a core value in our decision making process, to enable our values and our brand to last over time.



# Vulkan® Conical Connection Innovation, Precision and Quality

## R&D+i



Our Research, Development and Innovation team is made up of **engineers and doctors** with long, extensive and successful experience in the development of dental implants and prosthetic components. Together, they investigate and design the Vulkan® Implants **innovative products** according to user needs under the most **advanced protocols of Medical Engineering** and in accordance with **UNE 166002**.

## STATE-OF-THE-ART-TECHNOLOGY



Vulkan® products are known for their **high precision, quality and robustness**. This is possible, among other things, thanks to the **skillfulness of our specialists**, experts in dental technology, and the latest CNC machinery which allow us to guarantee **tolerances of only 5 µm**. We can proudly say that our products are manufactured with **a very accurate technological system**.

## BEST QUALITY GUARANTEED

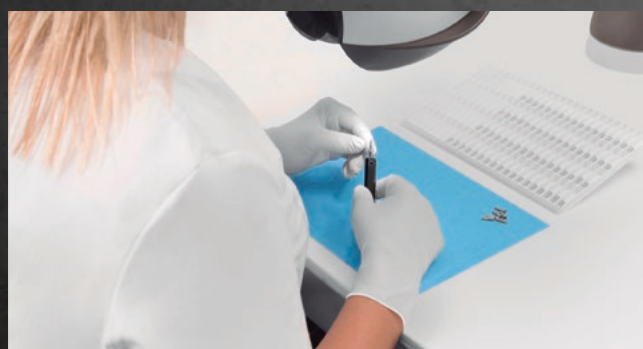

Our Quality Control Department applies the more **rigorous control system** and has been certified under the most strict European quality standards. Robotized computer machines with **artificial vision** analyze and ensure the precise measurement of each implant and prosthetic component. Also, through an innovative **optical laser** technology, we inspect up to the most micrometric detail of the implants or prosthetic components. Finally, to ensure the perfect functionality of our product, our team physically check the perfect fit of each item. **100% unitary control**.

## European Quality Standards

ISO 9001



ISO 13485



IQNet



CE Marking



AEMPS Licence



# Vulkan® Conical Connection XBody

---

## Ideal for post-extraction immediate implants

The conical Xbody design core increases soft bone compression. This design is especially beneficial in situations of low bone density.

## Ideal for immediate loading

The conical core and the self-tapping thread shape provide greater primary stability with less milling.

## Greater stability of the peri-implant bone tissue

The inverted cone of the coronal region promotes the creation of long-term stable bone tissue.

## More prosthetic solutions

Introducing Vulkan Tissue Care, the transepithelial attachment for single or multiple restorations that transfers the prosthetic platform from the bone level to the tissue level, reducing risks and time in the treatment.

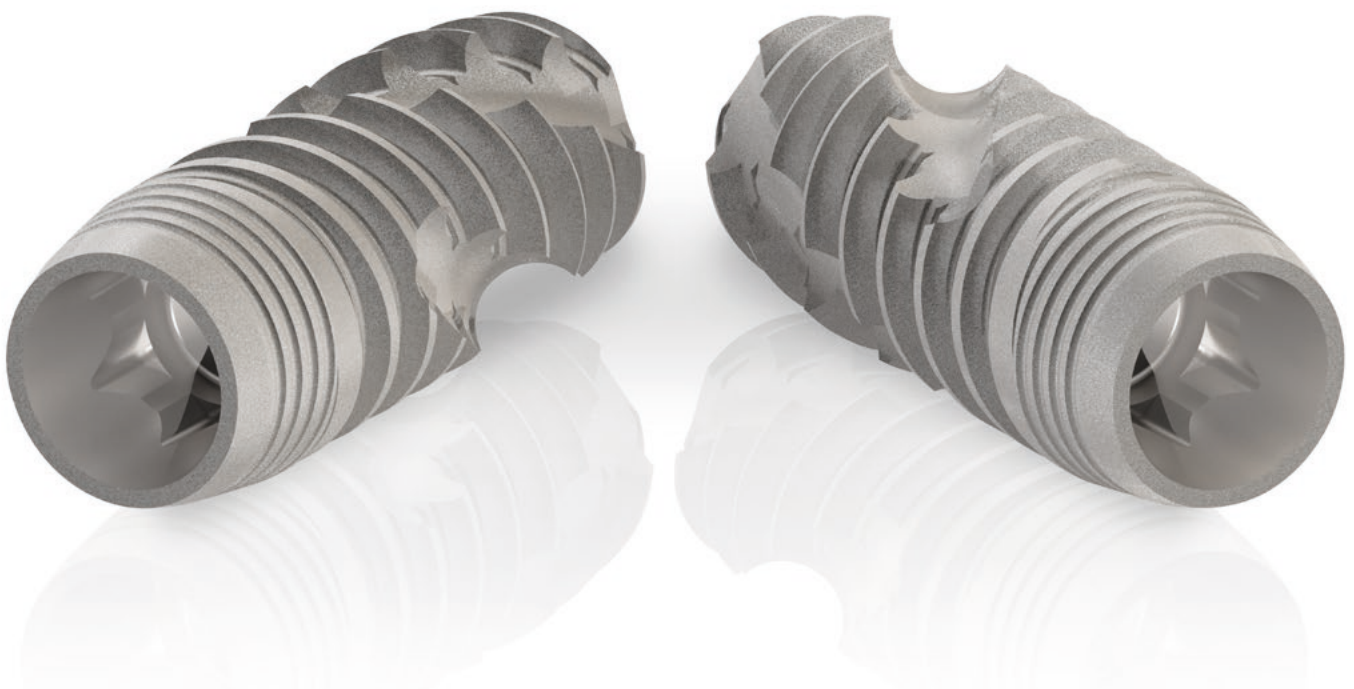

# TESTED BENEFITS

---

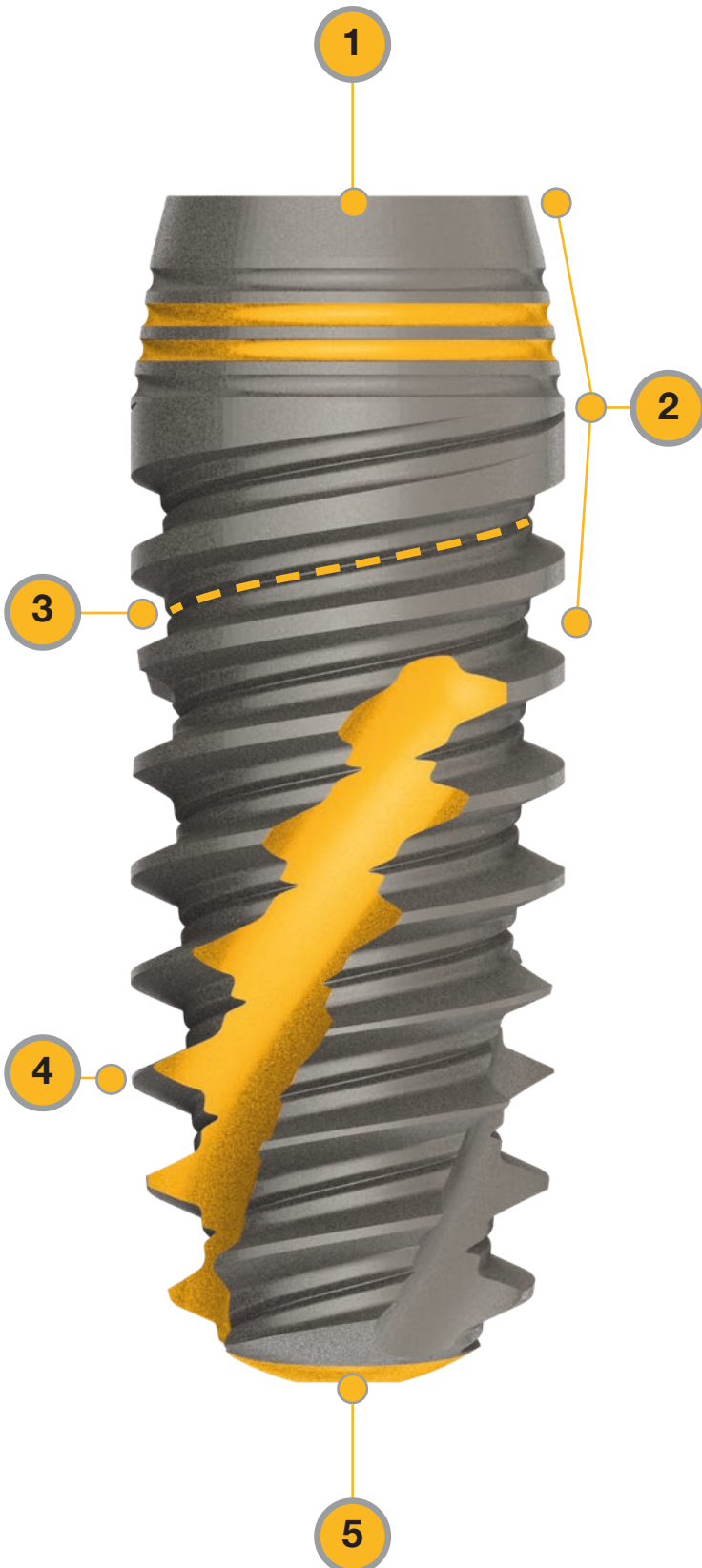

## 1. Optimal sealing

The conical profile in 12° guarantees optimum sealing, minimizing micro filtrations. In addition, the Vulkan Conical Connection system simplifies prosthetic procedures with a single prosthetic connection for the main four implant diameters.

## 2. Increase the bone tissue

The Xbody design is marked by the shape of an inverted cone in the coronal region of the implant along with the platform switching, maximizing the volume of bone and soft tissue and providing a natural-looking aesthetic for an optimal prosthetic result.

## 3. Easy movement of fluids

The micro grooves in thread design promote the circulation of fluids for an optimal and faster osseointegration.

## 4. Self-tapping

The morphological design of the implant along with the conical core provide a greater sense of control in the insertion and a greater primary stability with less milling.

## 5. Minimizes the risk of injury to anatomical structures

The blunt tip improves maneuverability in insertion and reduces the risk of injury.

# VLA® Surface treatment

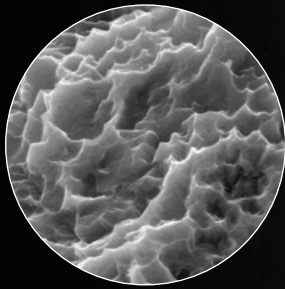

7.50k X

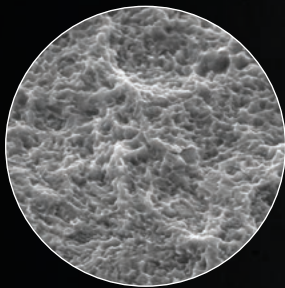

2.50k X

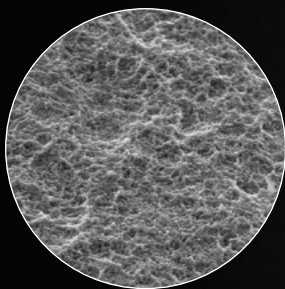

1.00k X

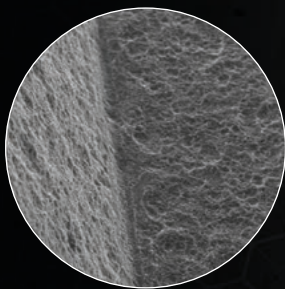

500 X

## Proven Guarantee of Success

The Vulkan® Conical Connection Implant has been subjected to a treatment consisting of **sandblasting + double acid etching** creating a surface with optimum roughness of 1.4 µm.

This is a widely studied surface that provides a microstructure that **stimulates the osseointegration** of the implant.

The VLA® surface treatment presents **success rates of 98%-99%**. This microstructure also ensures a large contact area between implant and bone, providing the **maximum BIC (Bone Implant Contact)**.

## The Cleanest Implant

In addition, an **innovative final cleaning technique** is applied using a **plasma** cleaning system that strikes the surface of the implant, subjecting it to an intensive blasting causing the detachment and **complete elimination of any possible remaining contaminants**.

Finally, the implant is subjected to a strict **sterilization** by gamma rays.

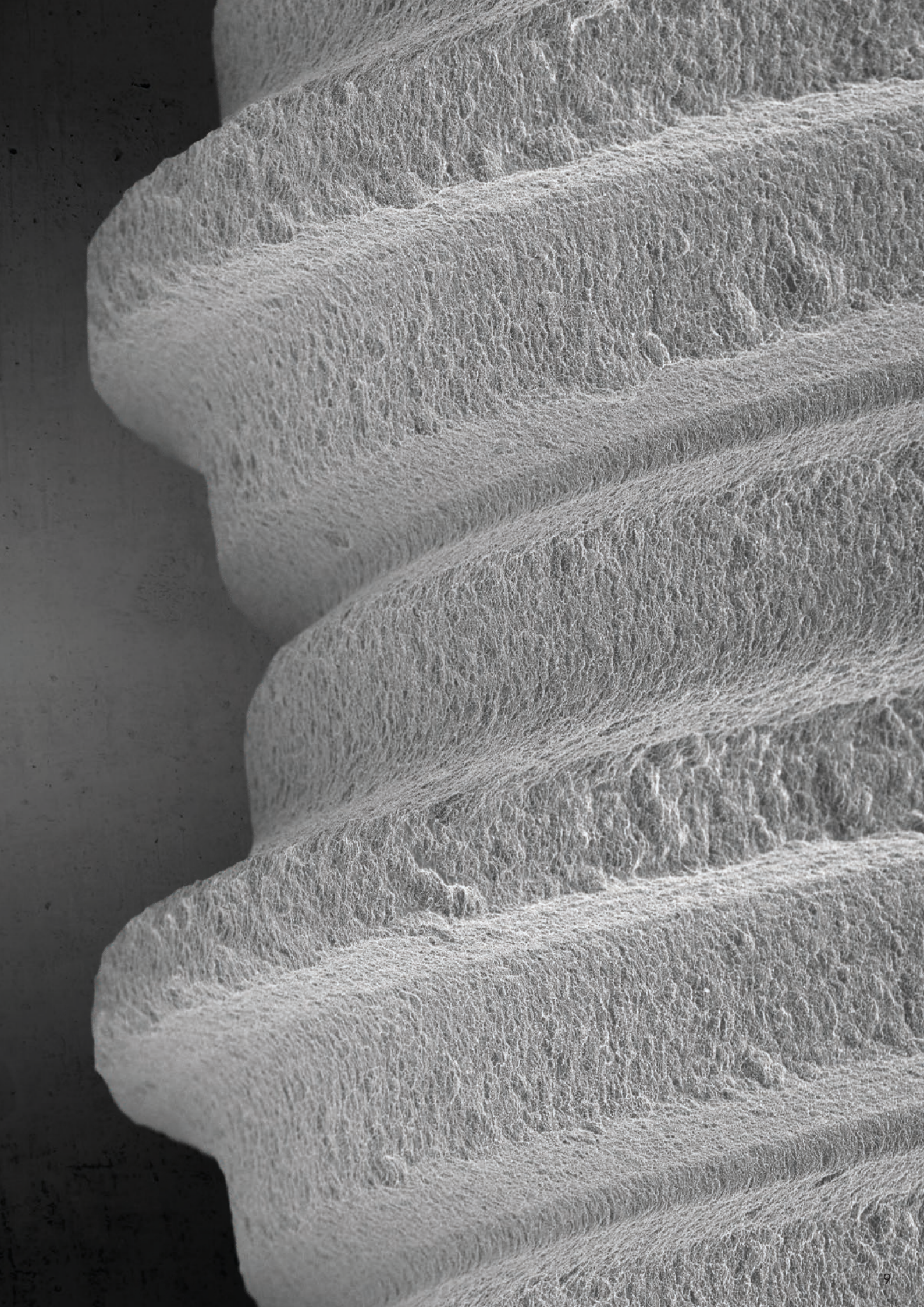

# Vulkan® Conical Connection

## Technical specifications



Platform: Ø3.0  
 Prosthetic connection: Ø2.47  
 Metrics: M-1.4

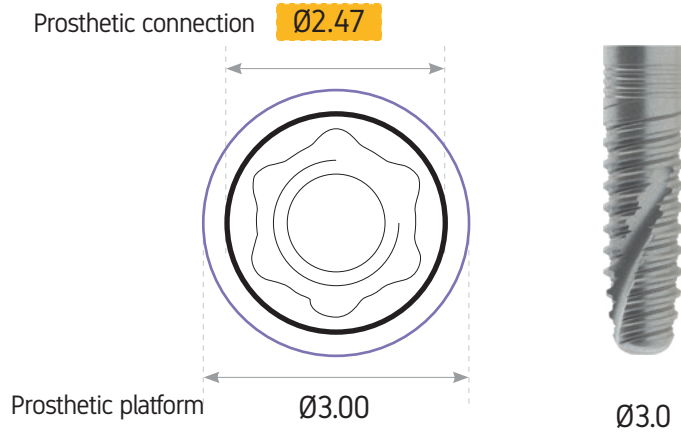

Platform: Ø3.5 - Ø3.8  
 Prosthetic connection Ø3.00  
 Metrics: M-1.6

4 diameters  
 1 single prosthetic connection

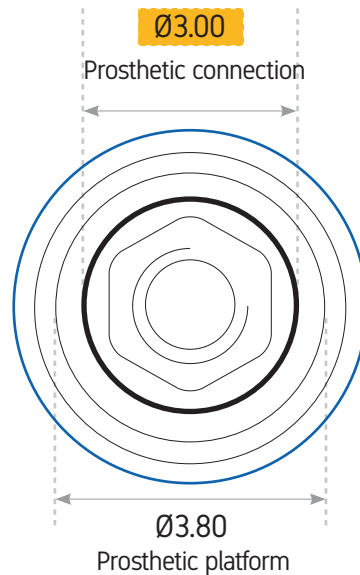
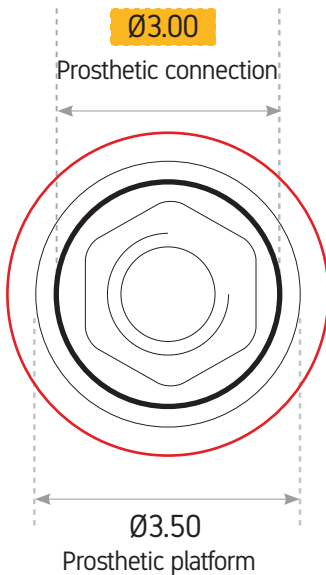
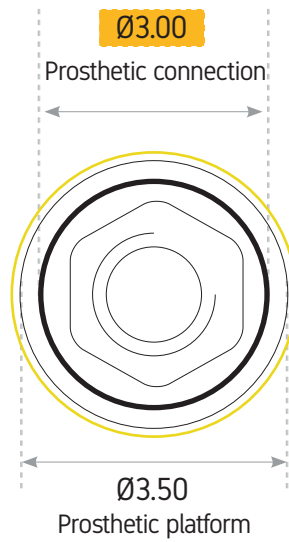
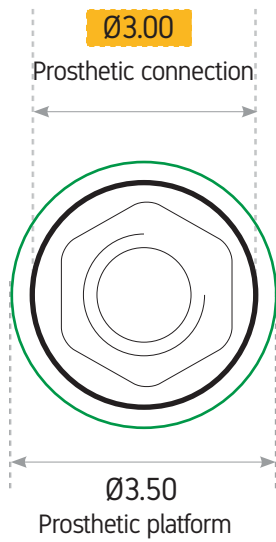

# Sizes Guide

Vulkan® Conical Connection   
The cutting-edge implant that meets all your needs

MiP  
3.0

TITANIUM  
4



Ø3.0x08    Ø3.0x10    Ø3.0x11,5    Ø3.0x13    Ø3.0x15



NP  
3.5

TITANIUM  
4



Ø3.30x08    Ø3.30x10    Ø3.30x11,5    Ø3.30x13    Ø3.30x15



NP  
3.5

TITANIUM  
4



Ø3.75x08    Ø3.75x10    Ø3.75x11,5    Ø3.75x13    Ø3.75x15    Ø3.75x18



NP  
3.5

TITANIUM  
4



Ø4.20x08    Ø4.20x10    Ø4.20x11,5    Ø4.20x13    Ø4.20x15    Ø4.20x18



NP  
3.5

TITANIUM  
4



Ø5.00x08    Ø5.00x10    Ø5.00x11,5    Ø5.00x13    Ø5.00x15



\*all Vulkan® Implants include the Cover Screw in the same pack.

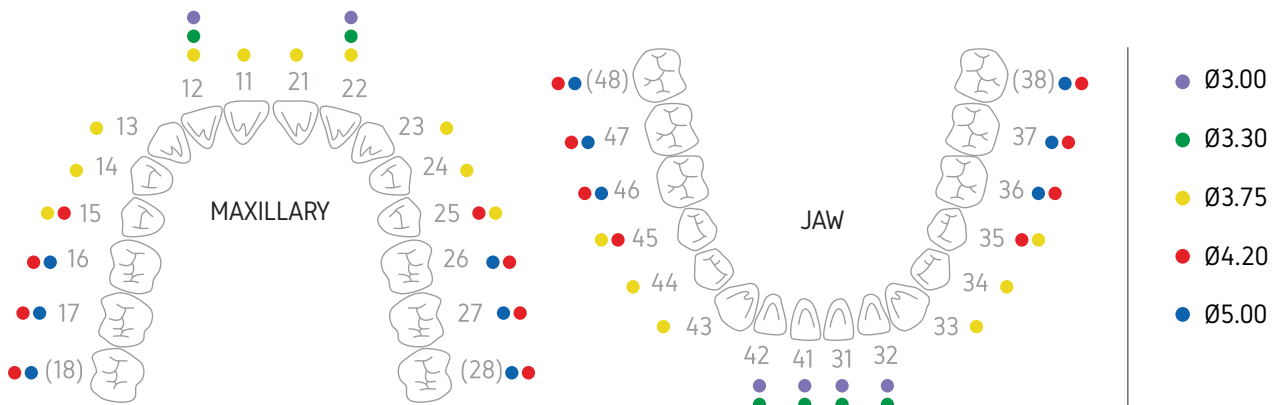

# Vulkan® Conical Connection

## Technical specifications



**Mip 3.0 platform** offers to the dental professional the possibility of performing dental implant treatment **in areas with limited spaces**.

The conical connection implant **with a 3.0 mm platform** is indicated for the anterior sector, **in lateral unitary incisors in the maxilla and lateral and central incisors in the jaw**.

The conical connection guarantees a **perfect seal**, reducing micro filtrations and guaranteeing the success of the treatment.

The **XBody** design of the implant body provides high levels of primary stability and bone preservation. Furthermore, it **facilitates the adjustment of the implant position during insertion** for optimal restoration orientation.



### Mip Platform allows

Treatment with dental implants in areas with limited spaces.

### Indicated for

- ✓ Unitary lateral incisors in maxilla.
- ✓ Lateral and central incisors in the jaw.

### Abutments available for Mip Platform:

Find all references on pages 22-29



Clousure screw



Healing Cap



Impression Coping



Analog



Castable



Cobalt-Chrome Castable



Temporary Abutment



## Technical specifications



**Vulkan Tissue Care** is an abutment system designed to **preserve connective tissue** and ensure complete **restorative and surgical flexibility**.

**Tissue Care abutments simplify the restorative** procedure by moving the prosthetic platform of the Vulkan® Conical Connection implants from the bone level to the tissue level, **remaining in position throughout the restorative procedure** and during the lifetime of the restoration.

This new position of the restorative platform allows the **soft tissue** to remain **intact** and facilitate an **optimal healing process**.

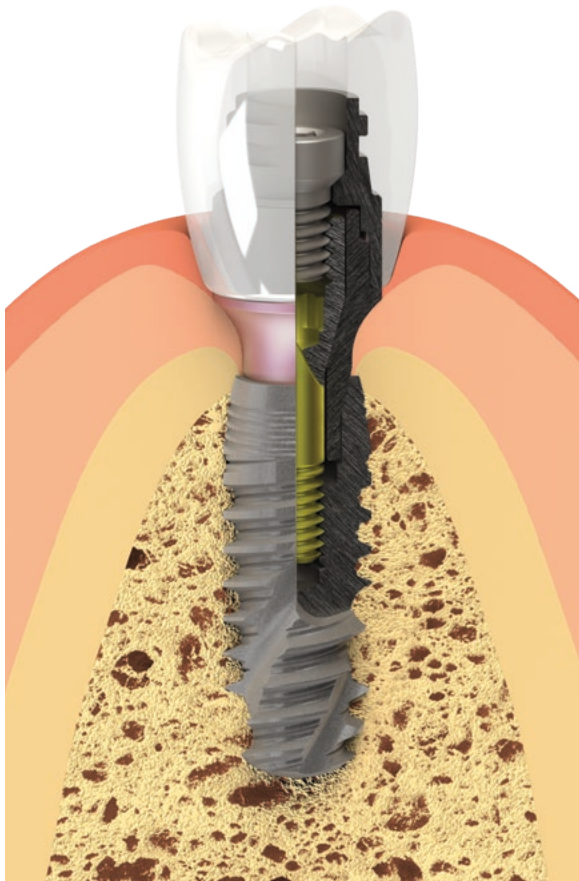
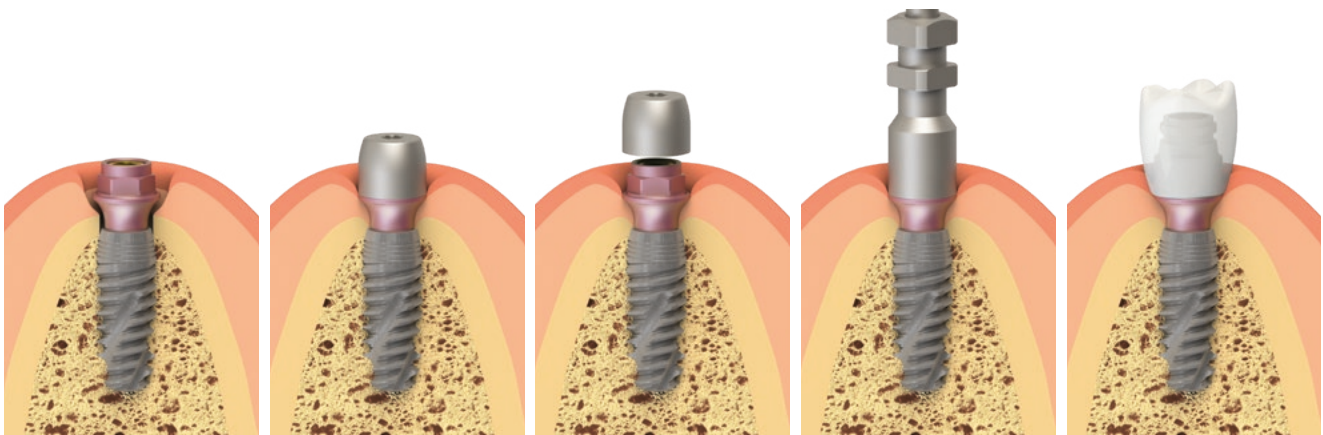

### Soft tissue preservation

**Tissue Care** abutments remain in position from implant placement to completion of the restorative procedure and the shelf life of the restoration.

### Simplification

**Tissue Care** abutments move the prosthetic platform of the Vulkan® Conical Connection implant from the bone level to the tissue level, facilitating the union of prosthetic components and the impression taking.

# Vulkan® Conical Connection

## Technical specifications



### The best titanium for the most advanced implant

In general, scientifically-proven dental implants are made of Titanium Grade 4. This material is known for providing better biocompatibility than Titanium Grade 5, because it has more pure titanium. However, although Titanium Grade 5 is less biocompatible, it has superior mechanical properties than Titanium Grade 4. This is the reason why Titanium Grade 5 is most commonly used in prosthetic components and Titanium Grade 4 in implants.

The determining factor in choosing between one material or another is their biocompatibility. However, it is also very important that the material contains mechanical properties that provide tensile/shear resistance, elasticity and enough strength/hardness to withstand the prosthetic process satisfactorily. That is why, in Vulkan we use an innovative material that provides the same biocompatibility than Titanium Grade 4 and the same mechanical properties than Titanium Grade 5.

### How do we manage to obtain the best of both materials in one?

Technically, the composition of our Titanium is Grade 4. However, when forming it we use a “Cold Forming” technique. This process to form the material is what provides our implants their superior mechanical properties.

Using this innovative technique, we manage to produce our implants for maximum biocompatibility and the best possible mechanical properties.

## Vulkan® Grade 4 Titanium “Cold forming”

- ✓ Higher strength
- ✓ Greater Biocompatibility
- ✓ Advanced Mechanical Properties

### Comparison of the different compositions of titanium

TITANIUM		MECHANICAL CHARACTERISTICS		
Description	State	Tensile strength N/mm <sup>2</sup>	0,2% Yield point N/mm <sup>2</sup> min.	Elongation %
Grade 2		345	230	20
Grade 3		450	300	18
Grade 4		550	440	15
<b>Grade 4 Vulkan®</b>	<b>Cold Forming</b>	<b>√ 850</b>	<b>√ &gt; 700</b>	<b>√ &gt; 10</b>
Grade 5		900	> 795	> 10

# Vulkan® Conical Connection

## Information prior to the surgical protocol

Vulkan® recommends a submerged insertion of the Conical Connection implant. For an optimal control of the milling depth, it is recommended to use the stoppers during the surgical protocol.

To facilitate this process, Vulkan® Drill Stoppers have the nominal milling depth indicated, varying from 6mm to 15mm. There are two designs of stoppers depending on the Ø of the drill. Series 1 (Drills of Ø2.50, Ø2.80, Ø3.20) and Series 2 (Drills of Ø3.65 and Ø4.60).

**The depth of implant insertion is responsibility of the surgeon.**

### Informative drill stoppers table:

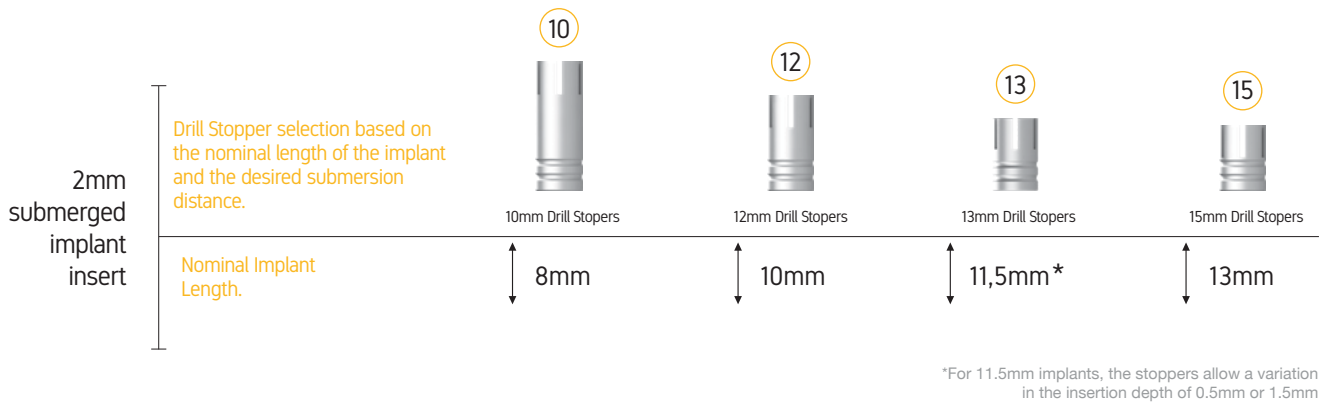

### Illustrative example\* Implant insertion Ø4.20X10 leaving 2mm of submersion

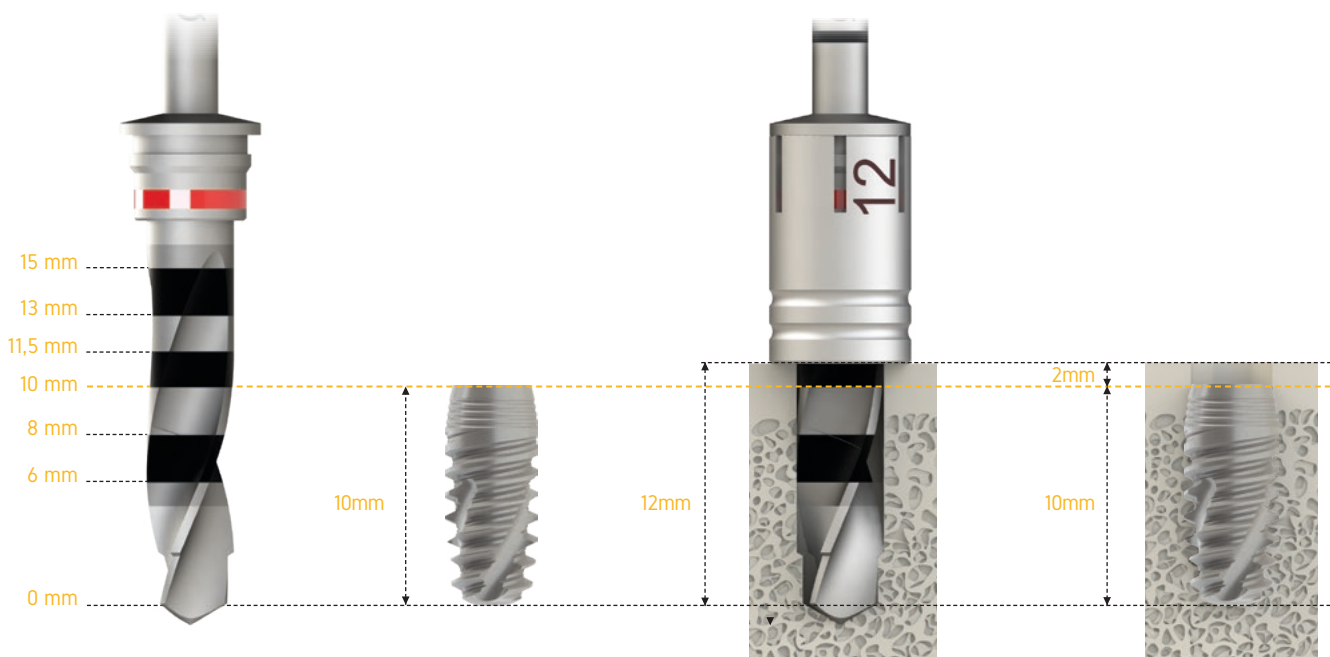

# Vulkan® Conical Connection

## Surgical Protocol

**These indications have been made for guidance (only).**

Bone drilling must be done carefully and taking into account the different bone density characteristics (Type I-IV).

### Important considerations (to be taken) during bone drilling:

- Use copious/profuse external irrigation of pre-refrigerated NaCl at 5°C solution.
- Prepare the implant bed site with sequential drilling (straight up-and-down motion during osteotomy).
- Drill the osteotomy using light pressure.

### Ø3.0mm

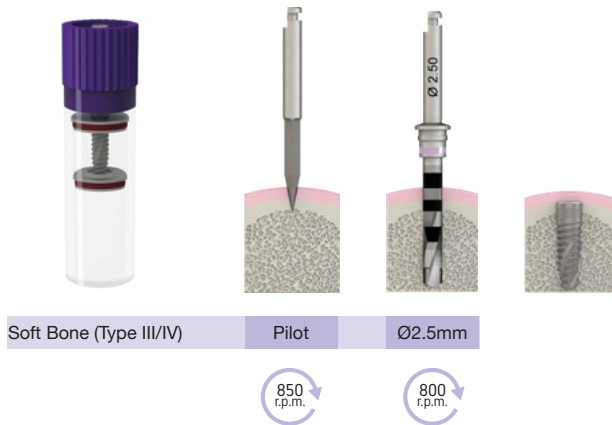

### Ø3.3mm

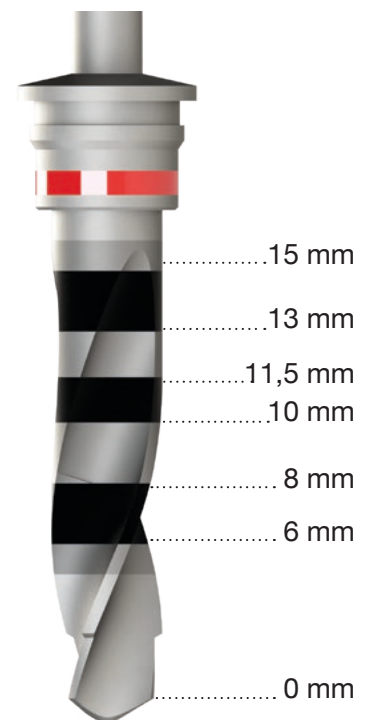
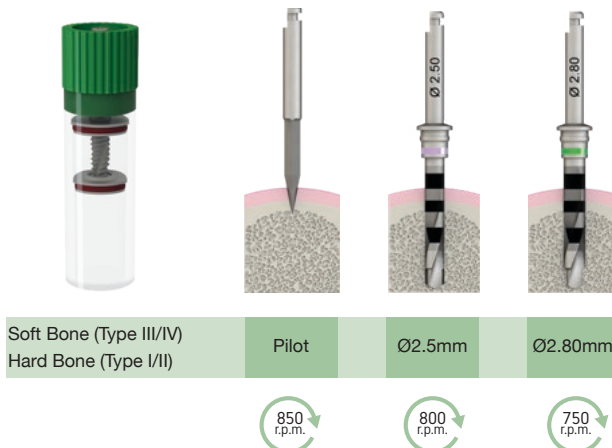

# Vulkan® Conical Connection

## Surgical Protocol

### Ø3.75mm

Soft Bone (Type III/IV) Hard Bone (Type I/II)	Pilot	Ø2.5mm	Ø2.80mm	Ø3.20mm	*Countersink Drill
	850 r.p.m.	800 r.p.m.	750 r.p.m.	650 r.p.m.	350 r.p.m.

### Ø4.2mm

Soft Bone (Type III/IV) Hard Bone (Type I/II)	Pilot	Ø2.5mm	Ø2.80mm	Ø3.20mm	Ø3.65mm	*Countersink Drill
	850 r.p.m.	800 r.p.m.	750 r.p.m.	650 r.p.m.	650 r.p.m.	350 r.p.m.

### Ø5.0mm

Soft Bone (Type III/IV) Hard Bone (Type I/II)	Pilot	Ø2.5mm	Ø2.80mm	Ø3.20mm	Ø3.65mm	Ø4.60mm	*Countersink Drill
	850 r.p.m.	800 r.p.m.	750 r.p.m.	650 r.p.m.	650 r.p.m.	550 r.p.m.	350 r.p.m.

# Vulkan® Conical Connection Smart Implant Driver

## Multifunctionality

Transports the implant by friction fit

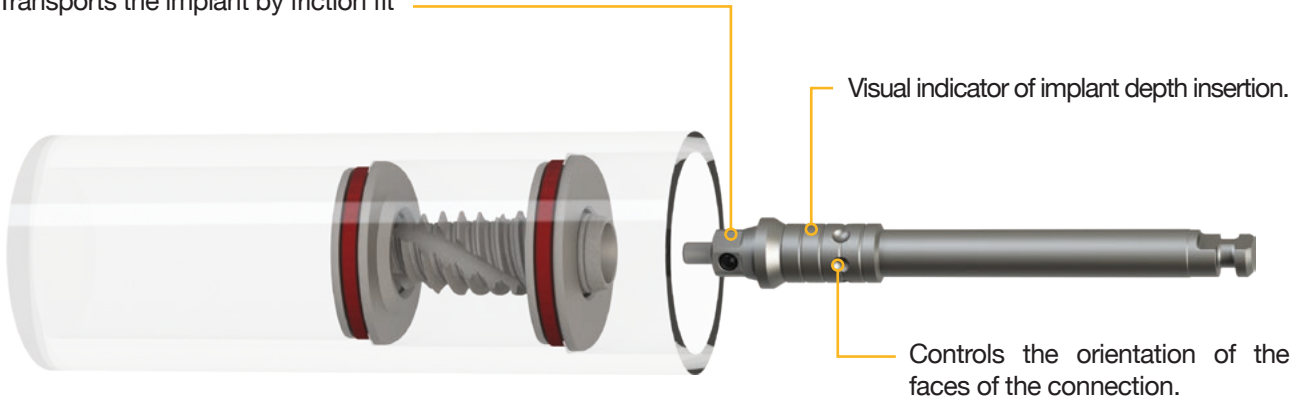



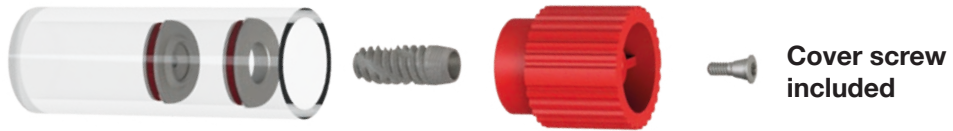

Titanium holders



### Contra-Angle Driver

**Short (21mm)**      **Long (27mm)**

- |  |  |
|--|--|
|  VCONDRS1 |  VCONDRS2 |
|  VCONDRN1 |  VCONDRN2 |

### Ratchet Driver

**Short (21mm)**      **Long (27mm)**

- |  |  |
|--|--|
|  VCONDRS3-R |  VCONDRS4-R |
|  VCONDRN3-R |  VCONDRN4-R |

### Squared Ratchet 4x4

**Short (21mm)**      **Long (27mm)**

- |  |  |
|--|--|
|  VCONDRS3 |  VCONDRS4 |
|  VCONDRN3 |  VCONDRN4 |



# Step-by-Step Implant Placement



## STEP 1

Lift off the coloured cap to open the vial containing the implant. Place the cap into a sterile field. The implant cover screw comes attached to the top of the cap.



## STEP 2

Attach the implant driver to the contra angle.



## STEP 3

Connect the contra angle driver to the implant by exerting slight axial pressure. They will remain attached because the driver presents an elastic retention feature (rubber dots) in the area that connects to the implant. Remove the implant from the vial and carry it to the implant bed.

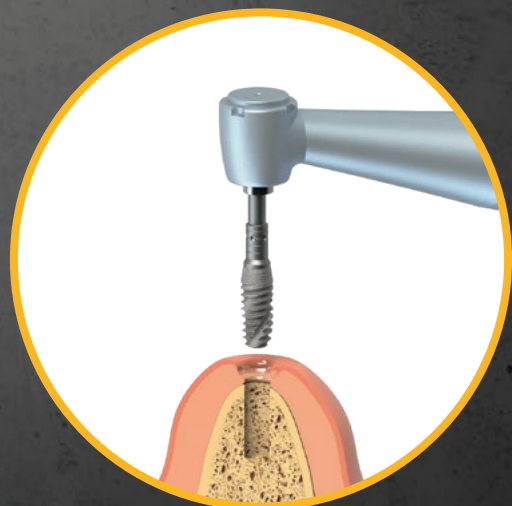

## STEP 4

Start the implant insertion with the contra angle set at low speed (10-15rpm) and a torque of 30-35 Ncm.

# Vulkan® Conical Connection Step-by-Step Implant Placement

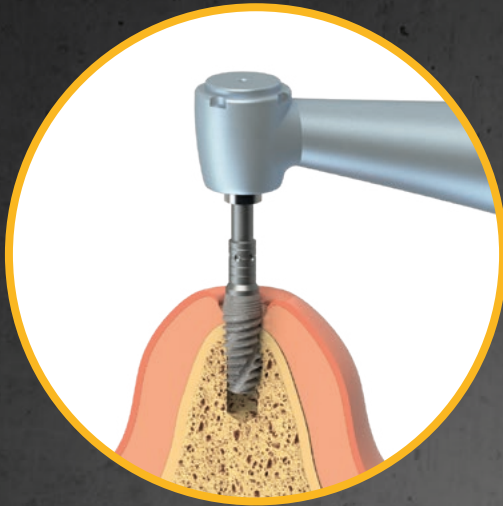

## STEP 5

Insert it up to the 75% implant length maintaining a maximum torque of 30-35 Ncm.



## STEP 6

Finalise the implant insertion using manual devices, preferably with the torque ratchet at a maximum torque of 40-45 Ncm. 1mm submersion position is recommended.



## STEP 7

Remove the cover screw from the vial cap using the Unigrip hand driver.

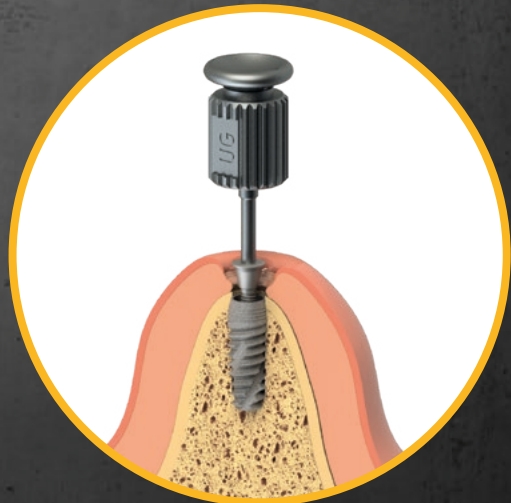

## STEP 8

Hand-tight the Cover screw into the implant manually. It is recommended not to exceed a torque of 10 Ncm.



**VULKAN**  
DENTAL IMPLANTS  
Strongly with you

# CONICAL CONNECTION ABUTMENTS



## Prosthetic Solutions and Tools

---

### Introduction

**Reliable and innovative** prosthetic solutions that ensure the **perfect fit** and maximum **robustness**.

As a result of our advanced manufacturing process, we obtain tolerances of **only 5 µm**, guaranteeing the absence of micro movements in the prosthetic components through an extremely **sealed and precise** connection.

### Index

#### Prosthetic Solutions and Tools

Basic Components _____	23-24
Transepithelial Multi-Use® System _____	25-26
Vulkan® Tissue Care System _____	27
Overdenture VulkanLoc® System _____	28
CAD-CAM Components _____	29
Prosthetic and Surgical Tools _____	30
Advanced Surgical Kit _____	31

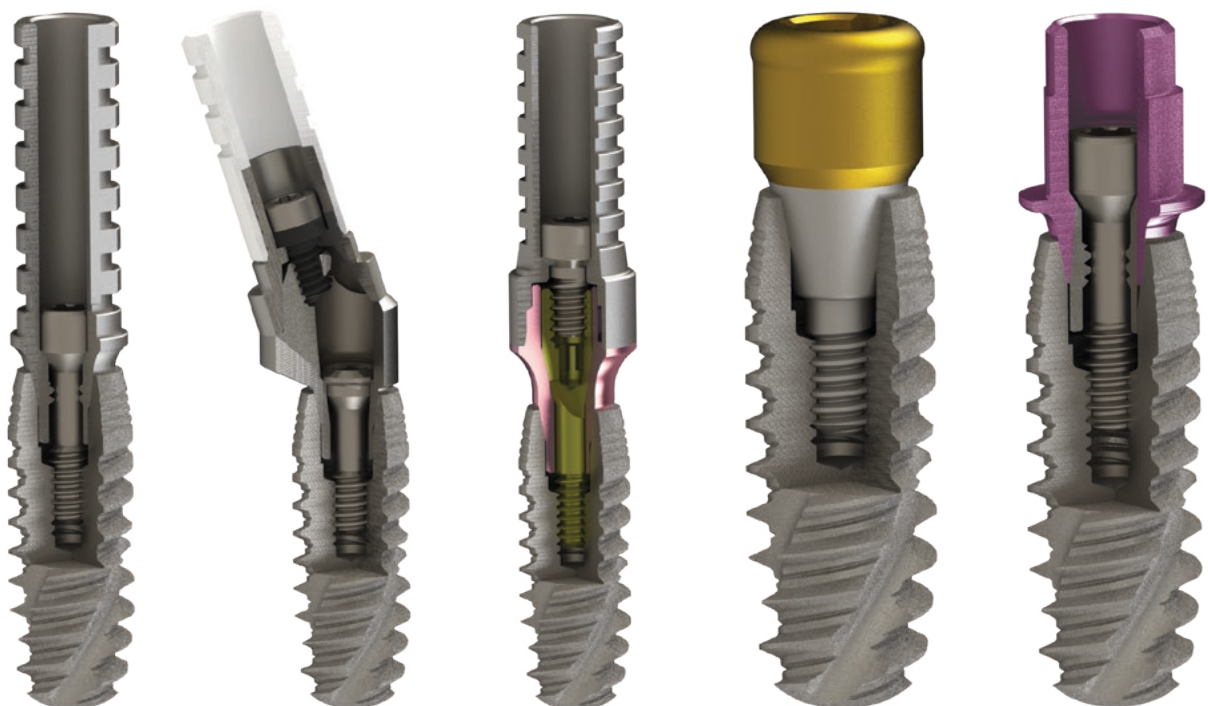

# Main Prosthetic Components

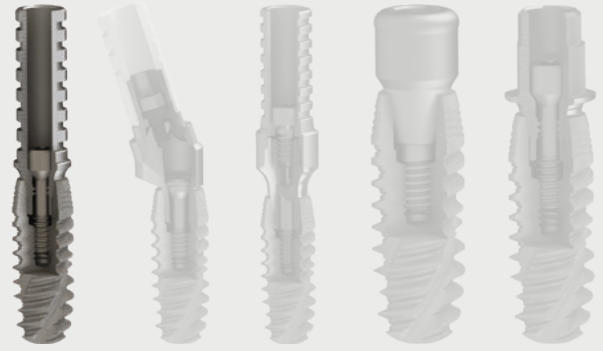

## Healing

Closure Screw



10 Ncm



Healing Cap - Emergency Ø3.2



20 Ncm



Healing Cap - Emergency Ø3.6



Healing Cap - Emergency Ø5.0

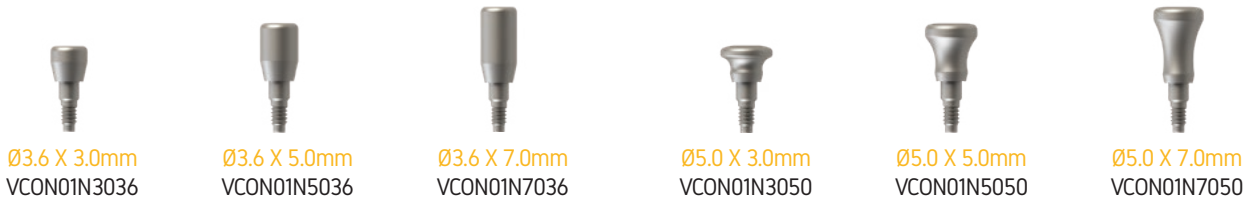

## Impression

Impression Coping



Analogue



# Main Prosthetic Components

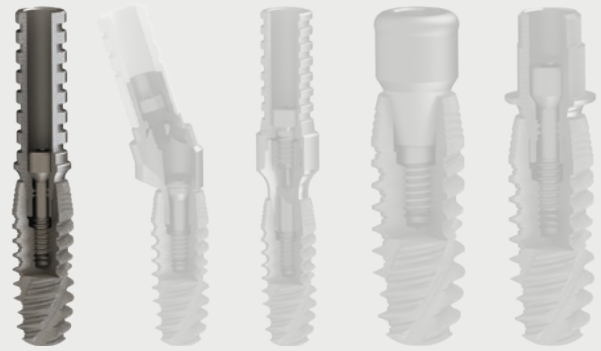

## Screw Retained Restoration

Castable



Cobalt-Chrome Castable



0051

Temporary Abutment



0051

Angled Cobalt-Chrome



CE 0051



0051

**ANTI ROT**

MiP 3.0 NP 3.5

VCON04S0001 VCON04N0001

VCON04S0002 VCON04N0002

**ROT**

MiP 3.0 NP 3.5

VCON05S0001 VCON05N0001

VCON05S0002 VCON05N0002

MiP 3.0 NP 3.5

VCON06S0001 VCON06N0001

VCON06S0002 VCON06N0002

17° 30°

1 VCHA170001 1 VCHA300001

2 VCON05N0003 2 VCON05N0003

17° 30°

1 VCHA170001 1 VCHA300001

2 VCON05N0004 2 VCON05N0004

## Cemented Prosthesis



0051

## Clinical Screw



0051

h1.5mm: VCON07N1501

h2.5mm: VCON07N2501

h3.5mm: VCON07N3501

h4.5mm: VCON07N4501

15°

15° h1.50 mm: VCON07N1515

15° h2.50 mm: VCON07N2515

15° h3.50 mm: VCON07N3515

25°

25° h1.50 mm: VCON07N1525

25° h2.50 mm: VCON07N2525

25° h3.50 mm: VCON07N3525

MiP 3.0 TITANIUM 5

max 15 Ncm

VCON09S07

TITANIUM DLC

VCON09S07T

NP 3.5 TITANIUM 5

max 25 Ncm

VCON09N07

TITANIUM DLC

VCON09N07T

## Angled Prosthetic Screws



0051

NP 3.5 TITANIUM 5

max 25 Ncm

VCON09N00-TLB

Short VSDTLB-1

Medium VSDTLB-2

Long VSDTLB-3

# Transepithelial Multi-Use®



## Multi-Use® Abutments

CE  
0051

### Multi-Use® Straight Abutments

TITANIUM 5 NP 3.5

30 Ncm



h1.5 mm  
VCON10N1500



h2.5 mm  
VCON10N2500



h3.5 mm  
VCON10N3500



h4.5 mm  
VCON10N4500



h5.5 mm  
VCON10N5500



h6.5 mm  
VCON10N6500

### Multi-Use® Angled Abutments

TITANIUM 5 NP 3.5

30 Ncm



17° h2.5 mm  
VCON10N2517



17° h3.5 mm  
VCON10N3517



30° h3.5 mm  
VCON10N3530



30° h4.5 mm  
VCON10N4530

## Healing

CE  
0051

Healing Cap for Multi-Use® (Integrated screw)



TITANIUM 5 MU0102

## Impression

Impression Coping for Multi-Use®

TITANIUM 5



CE  
0051

Open Tray  
MU0211



CE

Closed Tray  
MU0202

Multi-Use® Analog

ACERO INOX



CE

MU03

# Transepithelial Multi-Use®



## Screw Retained Restoration

CE

CE 0051

CE 0051

Castable for Multi-Use®

Cobalt-Chrome Castable for Multi-Use®

Temporary Abutment for Multi-Use®



POM

MU0402



POM CR CO

MU0502



TITANIUM 5

MU0602



PEEK

MU0602P

## Prosthetic Screw Multi-Use®



CE

CE 0051

MAX 15 Ncm



TITANIUM DLC

MU0905T



TITANIUM 5

MU0905

## Prosthetic Screw Angled Multi-Use®

Angled Cobalt-Chrome Multi-Use®



17°

1 VCHA170001 CE  
2 MU0504 CE 0051



30°

1 VCHA300001 CE  
2 MU0504 CE 0051

## Prosthetic Screw Multi-Use® Angled



CE 0051

MAX 15 Ncm



TITANIUM 5

MU0900-TLB



Short VSDTLB-1  
Medum VSDTLB-2  
Long VSDTLB-3

## Straight Multi-Use® Driver



Contra-Angle VDMU-1

CE 0051



Ratchet VDMU-2

CE

## Multi-Use® Abutment VulkanLoc

TITANIUM 5

CE 0051



MU11R00

# Vulkan Tissue Care

\*Only for single prostheses



## Straight Tissue Care Abutment + Screw



## Tissue Care Screw



## Healing



## Impression



### Healing Cap for Tissue Care



TCS0102

### Impression Coping for Tissue Care



TCS0201



### Analog for Tissue Care



TCS0300

## Screwed prosthesis

### Castable Tissue Care



TCS0400

### Cobalt-Chrome Castable Tissue Care



TCS0500



### Temporary Abutment Tissue Care



TCS0600



### Clinical Screw Tissue Care



TCS0957T



TCS0957



## Angled Prosthesis

### Angled Cobalt-Chrome



1

2

3

1 VCHA170001 CE  
2 VCHA300001 CE  
3 TCS0500-A CE

### Angled Screw



TCS0900-TLB CE

# Overdenture VulkanLoc®

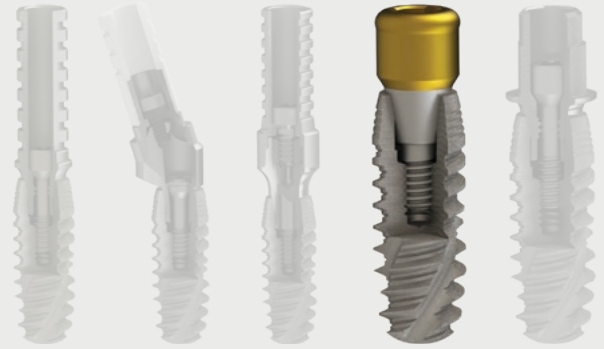

## VulkanLoc® Abutment

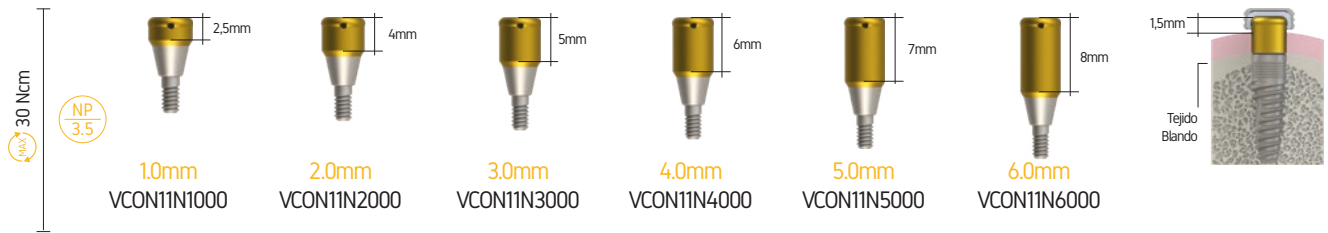

## VulkanLoc® Retainers



## VulkanLoc® Processing Package

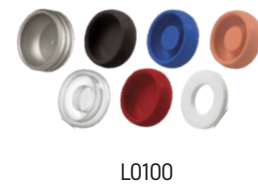
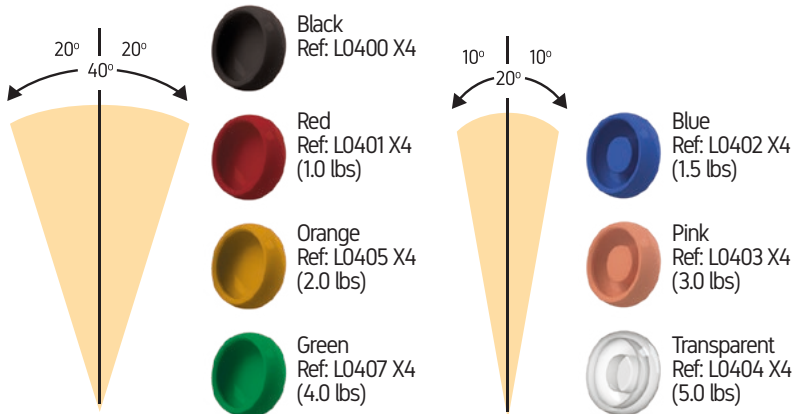

## Housing with Black Retainer



## VulkanLoc® Analog



## Mounter for VulkanLoc®



## Spacer Ring

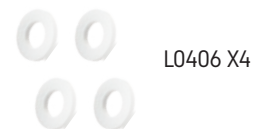

## Impression Coping for VulkanLoc®



## VulkanLoc® Driver



## Smart Tool VulkanLoc®



# CAD-CAM Components

\* Libraries Available:  
www.vulkanimplants.com

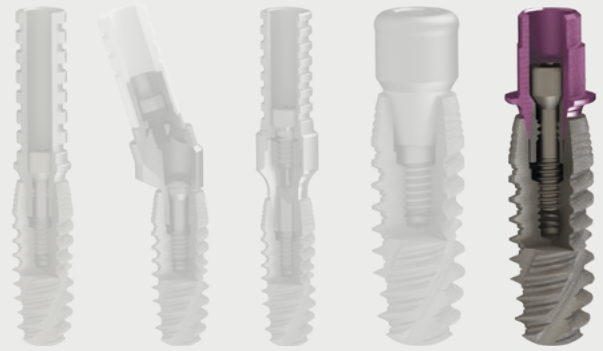

## Ti-Base MIP 3.0 CE 0051



ANTI  
ROT

h1.50 mm: VCON08S1501



ROT

h1.50 mm: VCON08S1502

## ScanBody TITANIUM 5 MIP 3.0 CE Analog STAINLESS STEEL MIP 3.0 CE



Intraoral  
VCON13S0002



VCON03S0010

## Ti-Base NP 3.5 CE 0051



ANTI  
ROT

h1.50 mm: VCON08N1501  
h2.50 mm: VCON08N2501  
h3.50 mm: VCON08N3501



ROT

h1.50 mm: VCON08N1502  
h2.50 mm: VCON08N2502  
h3.50 mm: VCON08N3502

## ScanBody TITANIUM 5 NP 3.5 CE Analog STAINLESS STEEL NP 3.5 CE



Intraoral  
VCON13N0002



VCON03N0010

## Ti-Base for transepithelial Multi-Use® CE 0051



ROT

h0.5mm:  
MU080502

## ScanBody Multi-Use® TITANIUM 5 CE Analog Multi-Use® STAINLESS STEEL CE



Intraoral  
MU13R02



MU0310

## Ti-Base for transepithelial Tissue Care CE 0051



ANTI  
ROT

h0.5mm:  
TCS080501

## ScanBody Tissue Care CE Analog Tissue Care CE



Intraoral  
TCS1301



TCS0310

## Surgical and Prosthetic Tools

### Prosthetic Drivers Unigrip

Hand Driver 

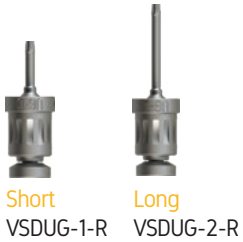

Hand Driver 



Ratchet Driver 4x4 



Adapters



### Tetralobular Prosthetic Drivers

For angled screw



### Implant Driver

<b>Contra-Angle</b> 		<b>Ratchet</b> 		<b>4x4</b> 	
Short (21mm)	Long (27mm)	Short (21mm)	Long (27mm)	Short (21mm)	Long (27mm)
					
VCONDRS1	VCONDRS2	VCONDRS3-R	VCONDRS4-R	VCONDRS3	VCONDRS4
<b>Contra-Angle</b> 		<b>Ratchet</b> 		<b>4x4</b> 	
Short (21mm)	Long (27mm)	Short (21mm)	Long (27mm)	Short (21mm)	Long (27mm)
					
VCONDRN1	VCONDRN2	VCONDRN3-R	VCONDRN4-R	VCONDRN3	VCONDRN4

Paralleling Pin (with depth marks) 



Drill Extender 



Spherical Drill 



### Surgical Drills



### Drill Stoppers

Serie 1 for Drills:  
Ø2.50 / Ø2.80 / Ø3.20



Serie 2 for Drills:  
Ø3.65 / Ø4.60



# Vulkan® Implants

## Advanced Surgical Kit



\*Stoppers

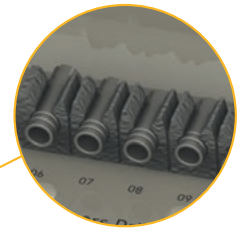

VSK- CON  
Dynamometric ratchet VDIN2  
Drivers Ø7 connection  
Drill Stoppers not included

VSK- CON-T  
Dynamometric ratchet VDIN2  
Drivers Ø7 connection  
Drill Stoppers included

VSK2- CON  
Dynamometric ratchet VDIN  
Drivers 4X4 connection  
Drill Stoppers not included

VSK2- CON-T  
Dynamometric ratchet VDIN  
Drivers 4X4 connection  
Drill Stoppers included



Dynamometric ratchet VDIN2



Spring Ratchet VDIN

### Vulkan® Surgical Kit contains

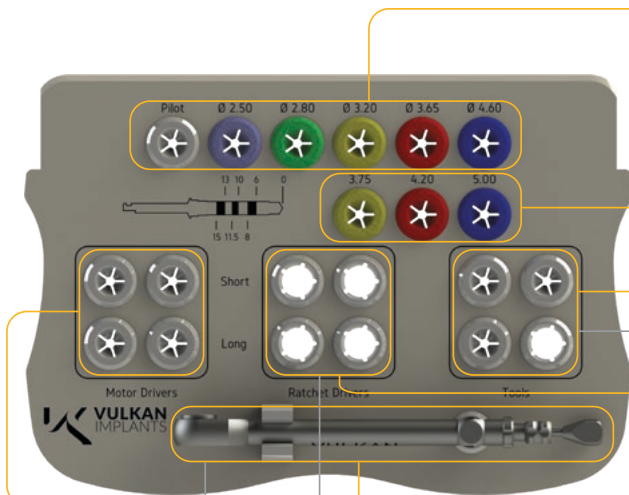

- VFP Vulkan® Pilot Drill
- VFT 25 Vulkan® Drill Ø 2.5
- VFT28 Vulkan® Drill Ø 2.8
- VFT32 Vulkan® Drill Ø 3.2
- VFT365 Vulkan® Drill Ø 3.65
- VFT460 Vulkan® Drill Ø 4.60
- VFAV375 Vulkan® Countersink Drill Ø3.75
- VFAV420 Vulkan® Countersink Drill Ø4.20
- VFAV500 Vulkan® Countersink Drill Ø5.00
- VG20 (x2) Vulkan® Paralleling Pin Ø2.0
- VDL Vulkan® Drill Extender
- VSDUG-2-R Vulkan® Prosthetic Hand / Ratchet Driver Unigrip Long
- VCONDRN-3 Vulkan® Conical Connection NP Implant Hand Driver Ratchet Short
- VCONDRN-4 Vulkan® Conical Connection NP Implant Hand Driver Ratchet Long
- VCONDRS-3 Vulkan® Conical Connection MIP Implant Hand Driver Ratchet Short
- VCONDRS-4 Vulkan® Conical Connection MIP Implant Hand Driver Ratchet Long
- VCONDRN1 Vulkan® Conical Connection NP Implant Driver Contra-Ángulo Corto
- VCONDRN2 Vulkan® Conical Connection NP Implant Driver Contra-Ángulo Largo
- VCONDRS1 Vulkan® Conical Connection MIP Implant Driver Contra-Ángulo Corto
- VCONDRS2 Vulkan® Conical Connection MIP Implant Driver Contra-Ángulo Largo
- VDIN2 Vulkan® Dynamometric Ratchet 10-70 Ncm (4x4 / Ø 7)

#### BASIC VERSION WITH 4X4 DRIVERS

- VCONDRN3 Vulkan® Conical Connection NP Implant Driver Ratchet Short
- VCONDRN4 Vulkan® Conical Connection NP Implant Driver Ratchet Long
- VCONDRS3 Vulkan® Conical Connection Mip Implant Driver Ratchet Short
- VCONDRS4 Vulkan® Conical Connection Mip Implant Driver Ratchet Long
- VDUG-2 Vulkan® Unigrip Ratchet Driver Long
- VDIN Vulkan® Spring Ratchet

VK



XBODY

[www.vulkanimplants.com](http://www.vulkanimplants.com)

## Vulkan® Conical Connection Implant



**Titanimplant, S.L.**  
[www.titanimplant.net](http://www.titanimplant.net)

C/ General Manso, 28-38, Local 4  
08980 Sant Feliu de Llobregat  
Barcelona, España.

